

Frame Size K (300-400) Amperes



Product description:

Complying to IEC 60947-2,
Maximum continuous Ampere rating at 40°C Voltage 240/415V,
Frequency 50/60Hz

Ue Maximum	415V
Icu	25/36/50 kA
Ics	25/36/50 kA
Ui	1000V
Uimp	12kV

Dimension:	H	W	D	Weight Kgs.
3Pole	257	140	111.7	5.7
4Pole		185		7.5

Marking
CE

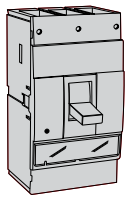
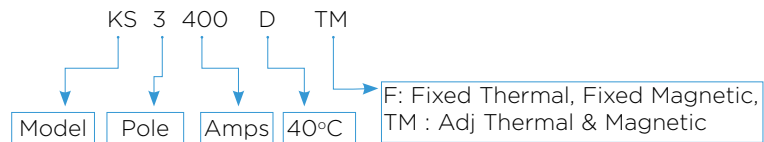

KI - Frame MCCB 25kA AT 415V (Fixed Thermal & Magnetic) 40°C

In (A)	3 pole		4 pole	
	Cat. No.	Ref.No.	Cat. No.	Ref.No.
300A	KI3300DF	W611325	KI4300DF	W611329
320A	KI3320DF	W611326	KI4320DF	W611330
350A	KI3350DF	W611327	KI4350DF	W611331
400A	KI3400DF	W611328	KI4400DF	W611332

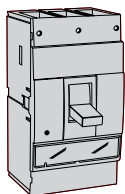

KS - Frame MCCB 36kA AT 415V (Fixed Thermal & Magnetic) 40°C

In (A)	3 pole		4 pole	
	Cat. No.	Ref.No.	Cat. No.	Ref.No.
300A	KS3300DF	W611333	KS4300DF	W611337
320A	KS3320DF	W611334	KS4320DF	W611338
350A	KS3350DF	W611335	KS4350DF	W611339
400A	KS3400DF	W611336	KS4400DF	W611340

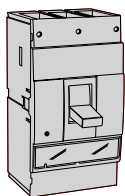

KS - Frame MCCB 36kA AT 415V (Adjustable Thermal & Magnetic) 40°C

In (A)	3 pole		4 pole	
	Cat. No.	Ref.No.	Cat. No.	Ref.No.
300A	KS3300DTM	W611341	KS4300DTM	W611345
320A	KS3320DTM	W611342	KS4320DTM	W611346
350A	KS3350DTM	W611343	KS4350DTM	W611347
400A	KS3400DTM	W611344	KS4400DTM	W611348

Frame Size K (300-400) Amperes

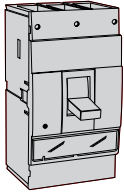

KH - Frame MCCB 50kA AT 415V (Adjustable Thermal & Magnetic) 40°C

50 kA	In (A)	3 pole		4 pole	
		Cat. No.	Ref.No.	Cat. No.	Ref.No.
		300A	KH3300DTM	W611349	KH4300DTM
320A	KH3320DTM	W611350	KH4320DTM	W611354	
350A	KH3350DTM	W611351	KH4350DTM	W611355	
400A	KH3400DTM	W611352	KH4400DTM	W611356	

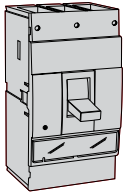

KSY - Frame MCCB (Non-Automatic) 40°C

	In (A)	3 pole		4 pole	
		Cat. No.	Ref.No.	Cat. No.	Ref.No.
		300A	KSY3300D	W611357	KSY4300D
320A	KSY3320D	W611358	KSY4320D	W611362	
350A	KSY3350D	W611359	KSY4350D	W611363	
400A	KSY3400D	W611360	KSY4400D	W611364	

Frame Size K (300-400) Amperes

Drawing

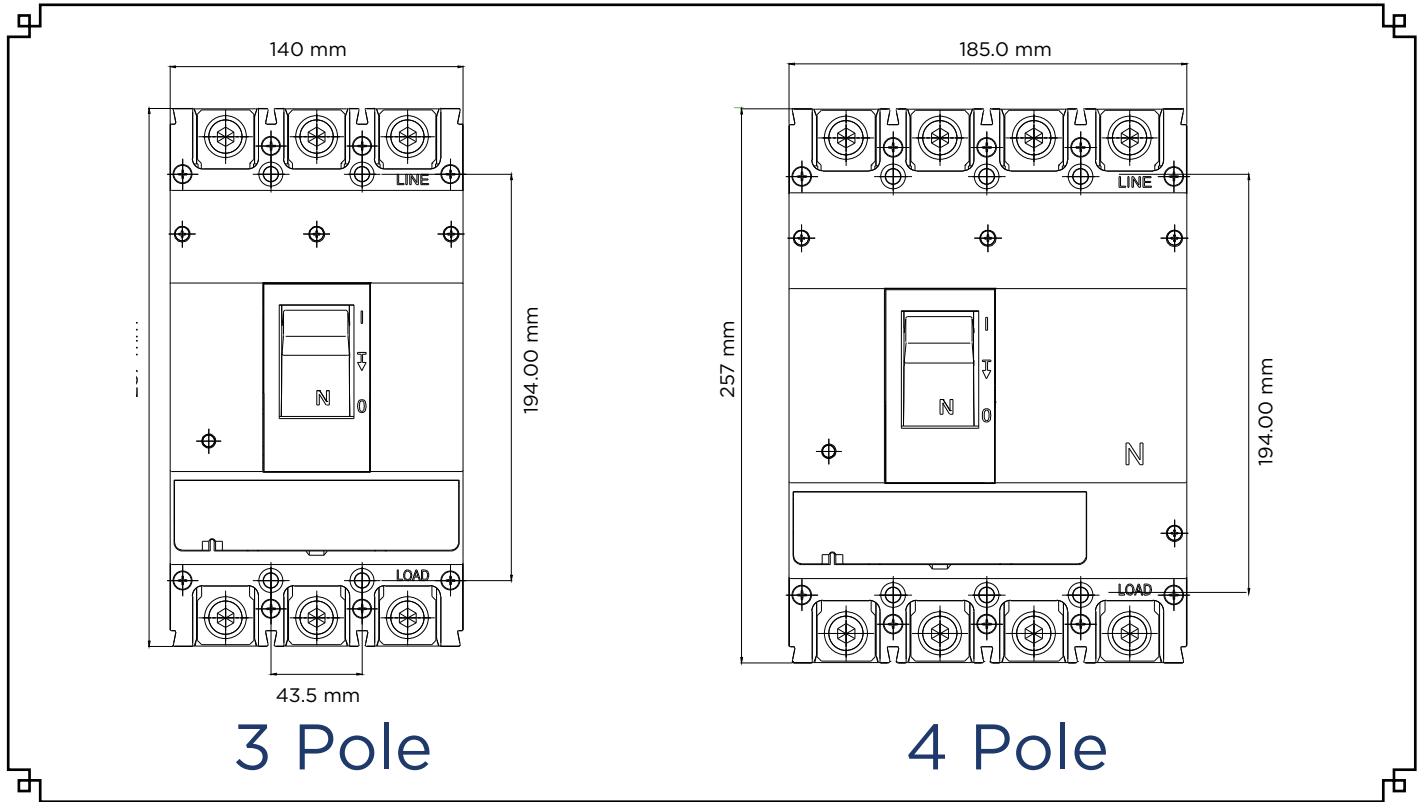

3 Pole

4 Pole

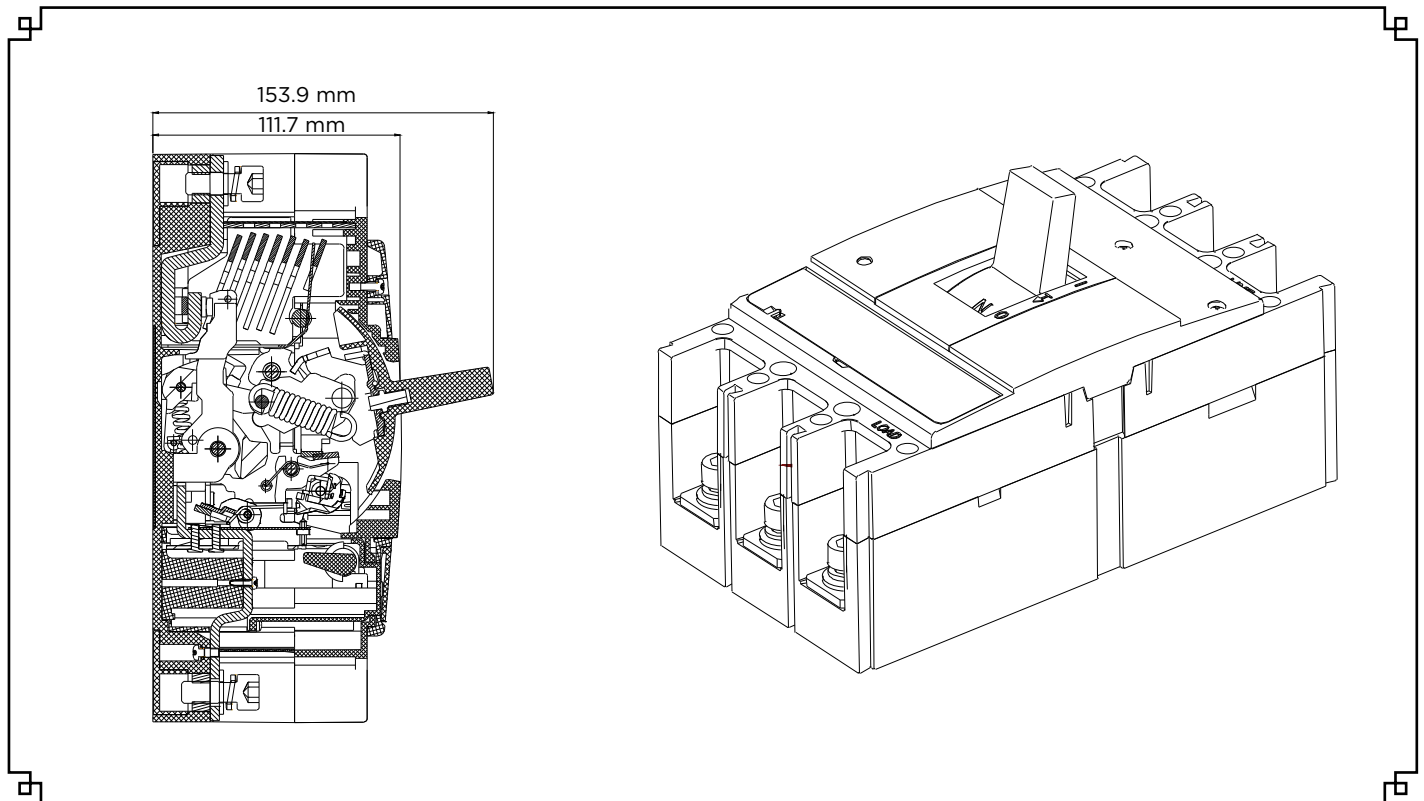

1
Moulded Case Circuit Breakers